



Domodedovo International Airport is among the largest and fastest growing airports in Russia, and a leader in domestic and international cargo operations. In order to meet ever growing capacity requirements, Domodedovo's refuelling company East Line contracted M+F for supplying an Aviation Fuel handling and Management System meeting latest technological standards.

The system includes:

- Design engineering for total solution of jet fuel handling
- Metering systems for product reception from pipeline
- Metering systems for product reception from railcars
- Level gauge systems for tanks
- Loading systems for loading of refueller trucks
- Pump systems for loading of refueller trucks
- On truck meter controller MFX\_4 with Radio LAN communication
- Metering systems with online communication on refueller and dispenser trucks
- Aviation Fuel Handling and Management system [AFHMS]

## AVIATION FUEL HANDLING AND MANAGEMENT SYSTEM [AFHMS]

The aviation fuel handling and management system is a PC-based system connected to a LAN. It is also connected to the airport scheduling system for optimized refuelling management.

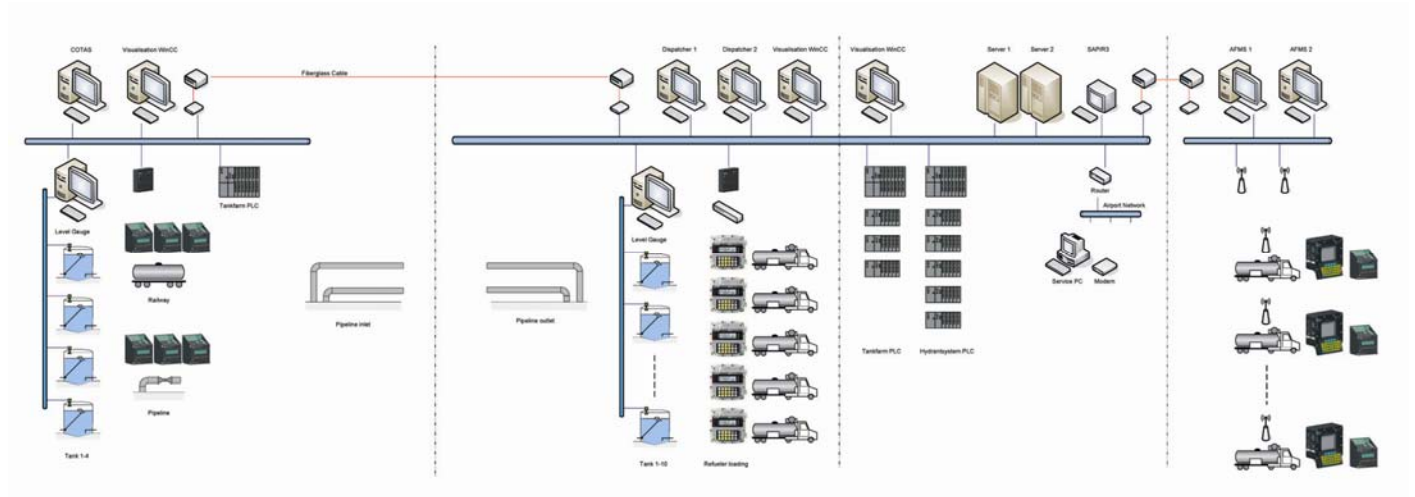

The entire field instrumentation communicates via OPC Server with AFHMS. Thus, AFHMS is connected to the following subsystems::

- Railcar unloading
- Pipeline receiving
- Tank farm inventory at the receiving point
- Tank farm inventory at the Apron
- Refueller loading
- Control system and pump control for the Refueller loading system
- Flow computer on the refueller and dispenser via RadioLan
- Interface to the airport scheduling system

The functionality of the system includes the following:

- Report for the receiving of the products via railcar unloading and pipeline
- Inventory control of the receiving tank farm
- Inventory control of the tank farm at the Apron
- Product delivery into the refueller
- Organisation of the refuelling contracts
- Monitoring of the refuelling into the aircraft
- Printing of the BOL
- Daily, monthly, yearly reports
- Book keeping for: into storage
- Book keeping for: into plane
- Entire balance of product flow

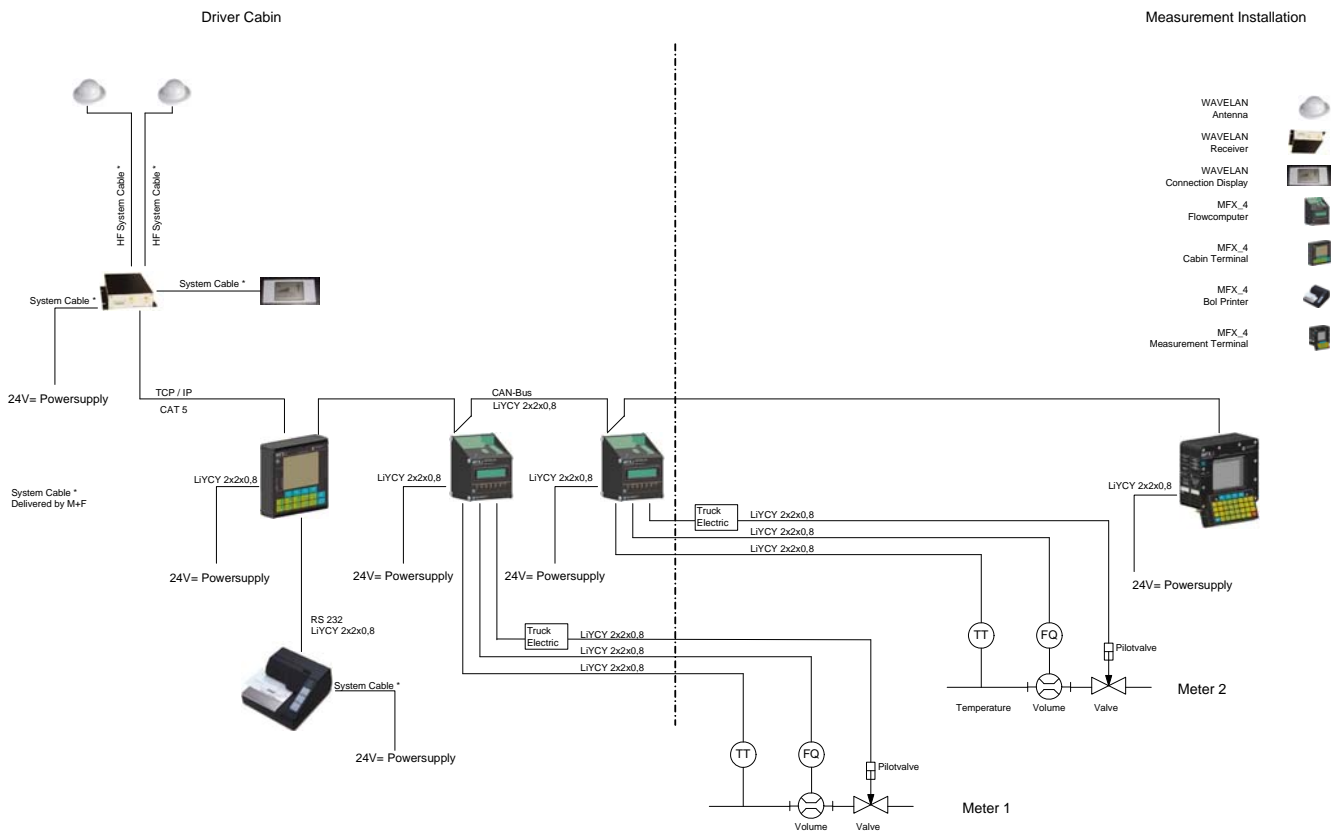

Meter Controller MFX\_4 installed on Dispenser/Refueller

